

## Glasbearbeitungen

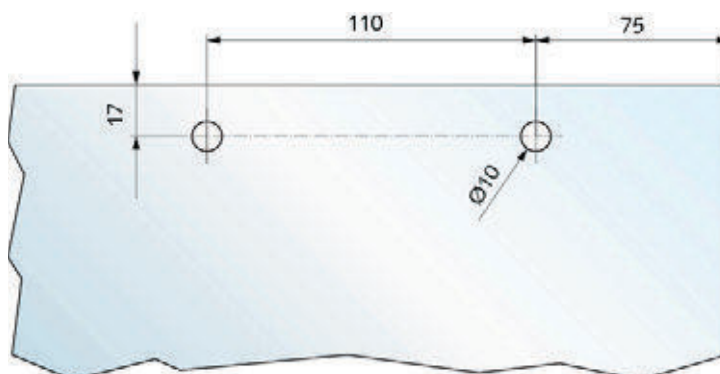

NOVA 180: Laufwagen (VSG)

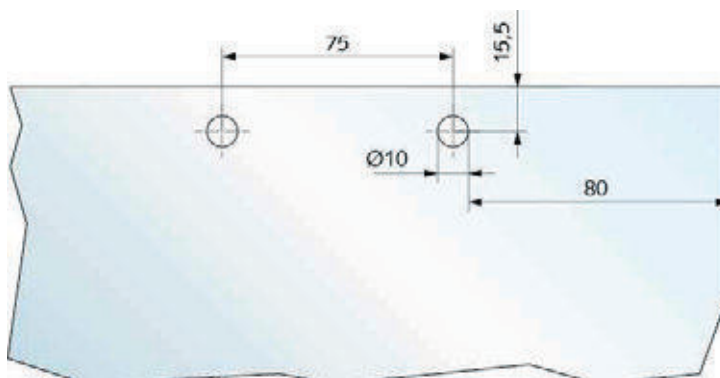

PURA 150: Laufwagen (VSG)

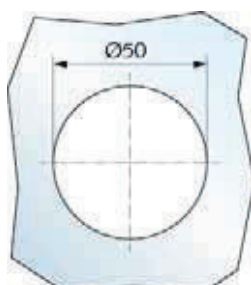

**Schiebetürmuscheln**  
Art.-Nr.  
28.204.0600.112 bis  
28.206.0500.426

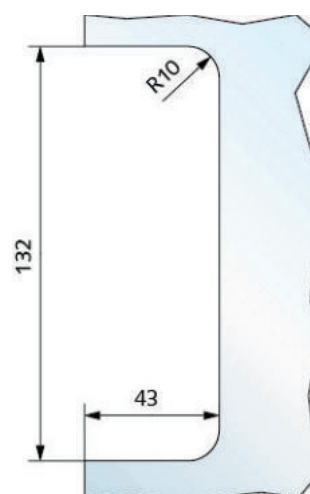

**Hakenriegelschlösser**  
Art.-Nr.  
28.210.0600.112 bis  
28.211.0620.426  
**Gegenkästen**  
Art.-Nr.  
28.214.0600.112 bis  
28.215.0600.426