



# GLASBAUBESCHLÄGE

für Duschen & Innentüren

GLASS HARDWARE  
for showers & interior doors



## MIT TRADITION, HANDWERK & LEIDENSCHAFT

Unsere Beschläge fertigen wir in der Regel aus hochwertigem und solidem Messing, in Sonderheit die für den Sanitärbereich. Messing ist ein sehr langlebiges und vielseitiges Material, mit einigen entscheidenden Vorteilen:

- **Sicherheit.** Messing ist nicht nur stabil, sondern hat gleichzeitig eine gewisse Flexibilität. Schon die alten Seefahrer wussten nicht nur die Druck, sondern auch die Schlagfestigkeit zu schätzen: große Vorteile gegenüber spröderen Metallen.
- **Oberflächen.** Neben den sehr guten Werten bei der Korrosions beständigkeit lässt sich Messing hervorragend polieren und besonders mit galvanischen Oberflächen veredeln, z.B. mit Chrom. Messing wird dementsprechend vielfältig in der Sanitärindustrie als Basismaterial für Armaturen genutzt.
- **Sonderlösungen.** Messing lässt sich mit der richtigen Manufakturereinrichtung gut zerspanen und bearbeiten und bietet gleichzeitig beste Voraussetzungen für verschiedenste Oberflächen.

Nicht nur bei der Auswahl der Materialien setzen wir auf Hochwertigkeit. Bis heute steht Handarbeit als Garant für gute Qualität – und das zu Recht. Unsere Produkte werden fast ausschließlich in unserer Manufaktur in Waldbröl händisch gefertigt. Materialauswahl und Fertigung vor Ort dienen auch der Nachhaltigkeit, ein wesentliches Ziel unseres Unternehmens.

Unser Team, bestehend u.a. aus Ingenieuren, Meistern und Glastechnikern, arbeitet stets daran, unsere Produkte in Funktionalität und Design zu perfektionieren. Auch bei der Fertigung von Sonderlösungen oder der Planung komplexer Projekte sind wir gerne Ihr Ansprechpartner und unterstützen Sie bei Ihrem Bauvorhaben.

## WITH TRADITION, PASSION & CRAFTSMANSHIP

We usually manufacture our fittings from high-quality and solid brass, at least those for use in the sanitary area.

Brass is a very durable and versatile material, with some key advantages:

- **Security.** Brass is not only stable, but also has a certain flexibility. Even the old time sailors appreciated not only the pressure- but also the impact resistance: great advantages over more rough metals.
- **Finishes.** In addition to the very good attributes for corrosion resistance, brass can be polished excellently and especially refined with plating finishes, e.g. with chrome. Accordingly, brass is widely used in the sanitary industry as a base material for fittings.
- **Custom Manufacturing.** Brass can be easily machined and processed with the right manufacturing equipment and at the same time offers the best conditions for a wide variety of finishes.

We do not only focus on high quality when selecting the materials. To this day, manual work is a guarantee of good quality – and rightly so. Our products are almost exclusively made by hand in our factory in Waldbroel, Germany. Material selection and on-site production also serve sustainability, a key goal of our company.

Our team, consisting of engineers, masters and glass technicians, is always working to perfect our products in terms of functionality and design. We are also happy to be your contact for the production of special solutions or the planning of complex projects and support you with our expertise.

### WICHTIGE HINWEISE IMPORTANT INFORMATION

Fertigungstechnische Toleranzen und Änderungen sind uns vorbehalten. Alle Angaben ohne Gewähr.

We explicitly reserve the right of production tolerances and changes in our products.

KL megl Germany GmbH ist alleiniger Inhaber der eingetragenen Wortmarke "KL megl". Sämtliche Inhalte dieser Publikation sind geistiges Eigentum der KL megl Germany GmbH und als solche urheberrechtlich geschützt. Die Vielfältigkeit, Bearbeitung, Verbreitung und jede Art der Verwertung außerhalb der Grenzen des Urheberrechtes bedürfen der schriftlichen Zustimmung der KL megl Germany GmbH, Waldbröl Deutschland. © KL megl Germany GmbH

KL megl Germany GmbH is the sole owner of the registered word mark "KL megl". All contents of this publication are the intellectual property of KL megl Germany GmbH and as such are protected by copyright. Duplication, processing, distribution and any kind of exploitation outside the limits of copyright law require the written consent of KL megl Germany GmbH, Waldbröl Germany. © KL megl Germany GmbH



---

5 JAHRE GARANTIE

5 YEAR WARRANTY

MADE IN GERMANY



5 JAHRE HERSTELLERGARANTIE AUF FOLGENDE PRODUKTE:

5 YEAR MANUFACTURER WARRANTY FOR THE FOLLOWING PRODUCTS:



Wellness, Wellness Premium, Wellness HS, Wellness HS CL, Fit, Next HS, Next HS CL, Milano Original Premium, Milano Original, Milano, Milano Pur, Chalet AT, Chalet PT, Stratego, Filigrano, Türgriffe Door Handles

# DUSCHTÜR BESCHLÄGE

## SHOWER DOOR HINGES







### ANSCHLAGTÜRSYSTEME

#### SINGLE ACTION DOOR SYSTEMS

	Wellness	10
	Wellness Premium	12
	Wellness HS	14
	Wellness HS CL	16
	CLASSTEC® Bella	18

### PENDELTÜRSYSTEME

#### DOUBLE ACTION DOOR SYSTEMS

	Milano	20
	Milano Pur	22
	Milano Original	24
	Milano Original Premium	26
	Next HS	28
	Next HS CL	30
	CLASSTEC® Vital	32

# CLASSTEC®

---

2 JAHRE GARANTIE

2 YEAR WARRANTY



2 JAHRE HERSTELLERGARANTIE AUF FOLGENDE PRODUKTE:  
2 YEAR MANUFACTURER WARRANTY FOR THE FOLLOWING PRODUCTS:

CLASSTEC® Bella, CLASSTEC® Vital

## ZUBEHÖR

### ACCESSORIES



Stabilisationsstangen &  
Handtuchhalter  
Support & Towel Bars

35



Türgriffe  
Door Handles

39

## GLASTÜRBESCHLÄGE

### GLASS DOOR HINGES

#### ANSCHLAGTÜRSYSTEM

##### SINGLE ACTION DOOR SYSTEM



Chalet AT

40

#### PENDELTÜRSYSTEM

##### DOUBLE ACTION DOOR SYSTEM



Chalet PT

42

## OBERFLÄCHEN, GRAVUR & VEREDELUNGEN









46

### FINISHES & ENGRAVING

# ÜBERSICHT

## OVERVIEW

- Entspricht der Spezifikation  
Corresponds to the specifications
- Oder nach innen öffnend  
Or inwards opening







								
	Wellness	Wellness Premium	Wellness HS	Wellness HS CL	CLASSTEC® Bella	Milano	Milano Pur	Milano Original
Anschlagtürsystem Opening outwards	■	■	■	●	●			
Pendeltürsystem Opening inwards and outwards						●	●	●
Hebe-Senk Mechanismus Gravity based lifting mechanism			●	●				
Flächenbündige Verschraubung Countersunk screws				●				
Für Rundduschen geeignet Suitable for round shower enclosures	●	●	●					
Ideal für Faltlösungen Ideal for folding solutions	●	●	●	●	●			
Badewannenaufsätze Bathtub glass screen	●	●	●	●	●			
Saunavarianten erhältlich Sauna type hinges available								●
Für Duschtürsysteme konzipiert Designed for Shower Door Systems	●	●	●	●	●	●	●	●
Nulllage stufenlos einstellbar Adjustable index position		●	●	●		●	●	●
Durchgehende Dichtung (By-Pass-System) Continuous seal (By-Pass-System)	●	●	●	●	●			
Selbstschließend, Softclose Self-closing, Softclose								
Vollabgedeckte Verschraubung Covered backplate, no visible screws			●		●			●
Wandanschraubplatte mit Langloch Wallbracket with slotted hole		●	●	●	●	●	●	
In das Band integrierte Dichtung Integrated seal in hinge								
Standard Glasstärke(n) in mm Standard glass thickness(es) in mm	8	8	8	8	8	8 & 10	8 & 10	8 & 10
Max. Türgröße in mm Max door size in mm	1000 x 2250	1000 x 2250	900 x 2250	900 x 2250	1000 x 2250	1000 x 2250	1000 x 2250	1000 x 2250
Max. Türgewicht Max door weight	40 kg	40 kg	35 kg	35 kg	40 kg	40 kg	40 kg	50 kg



# ÜBERSICHT

## OVERVIEW

- Entspricht der Spezifikation  
Corresponds to the specifications
- Oder nach innen öffnend  
Or inwards opening

	 Milano Original Premium	 Next HS	 Next HS CL	 CLASSTEC® Vital	 Chalet AT	 Chalet PT
Anschlagtürsystem Opening outwards					●	
Pendeltürsystem Opening inwards and outwards	●	●	●	●		●
Hebe-Senk Mechanismus Gravity based lifting mechanism		● +/- 5 mm	● +/- 5 mm			
Flächenbündige Verschraubung Countersunk screws			●			
Für Rurdduschen geeignet Suitable for round shower enclosures						
Ideal für Faltlösungen Ideal for folding solutions						
Badewannenaufsätze Bath tub glass screen						
Saunavarianten erhältlich Sauna type hinges available					●	
Für Duschtürsysteme konzipiert Designed for Shower Door Systems	●	●	●	●	○ optional	
Nulllage stufenlos einstellbar Adjustable index position	● 3-Punkt 3-Point	●	●	●		● +/- 2,5°
Durchgehende Dichtung (By-Pass-System) Continuous seal (By-Pass-System)						
Selbstschließend, Softclose Self-closing, Softclose					●	●
Vollabgedeckte Verschraubung Covered backplate, no visible screws	●	●			●	
Wandanschraubplatte mit Langloch Wallbracket with slotted hole	●	●	●			
In das Band integrierte Dichtung Integrated seal in hinge		●	●			
Standard Glasstärke(n) in mm Standard glass thickness(es) in mm	8 & 10	8 & 10	8 & 10	8	8	10
Max. Türgröße in mm Max door size in mm	1100 x 2250	1000 x 2250	1000 x 2250	1000 x 2000	1000 x 2100	1000 x 2500
Max. Türgewicht Max door weight	<b>50 kg</b>	<b>40 kg</b>	<b>40 kg</b>	<b>40 kg</b>	<b>45 kg</b>	<b>65 kg</b>

# WELLNESS



**EIGENSCHAFTEN**  
FEATURES

MAX. TÜRMASSE  
MAX. DOOR DIMENSIONS  
1.000 x 2.250 mm

GLAS (ESG)  
GLASS (TSG)  
8 mm

TÜRGEWICHT  
DOOR WEIGHT  
40 kg

**OBERFLÄCHEN**  
FINISHES

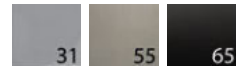

Sonderoberflächen möglich  
other finishes on request

**ANSCHLAGTÜRSYSTEM**  
SINGLE ACTION DOOR SYSTEM

**FUNKTIONEN**  
FEATURES

Nach innen oder außen öffnend  
Durchgehende Dichtung (By-Pass-System)  
Für Rundduschen und Falttüren geeignet

Opening in- or outwards  
Continuous seal (By-Pass-System)  
Suitable for round showers and folding doors



ANSCHLAGTÜRSYSTEM  
SINGLE ACTION DOOR SYSTEM



# WELLNESS PREMIUM



**EIGENSCHAFTEN**  
FEATURES

MAX. TÜRMÄÙE  
MAX. DOOR DIMENSIONS  
1.000 x 2.250 mm

GLAS (ESG)  
GLASS (TSG)  
8 mm

TÜRGEWICHT  
DOOR WEIGHT  
40 kg

**OBERFLÄCHEN**  
FINISHES

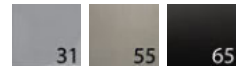

Sonderoberflächen möglich  
other finishes on request

**ANSCHLAGTÜRSYSTEM**  
SINGLE ACTION DOOR SYSTEM

**FUNKTIONEN**  
FEATURES

Einstellbare Nulllage  
Durchgehende Dichtung (By-Pass-System)  
Wahlweise nach innen oder außen öffnend  
Für Rundduschen und Falttüren geeignet

Adjustable index position  
Continuous seal (By-Pass-System)  
Opens inwards or outwards  
Suitable for round showers and folding doors





# WELLNESS HS

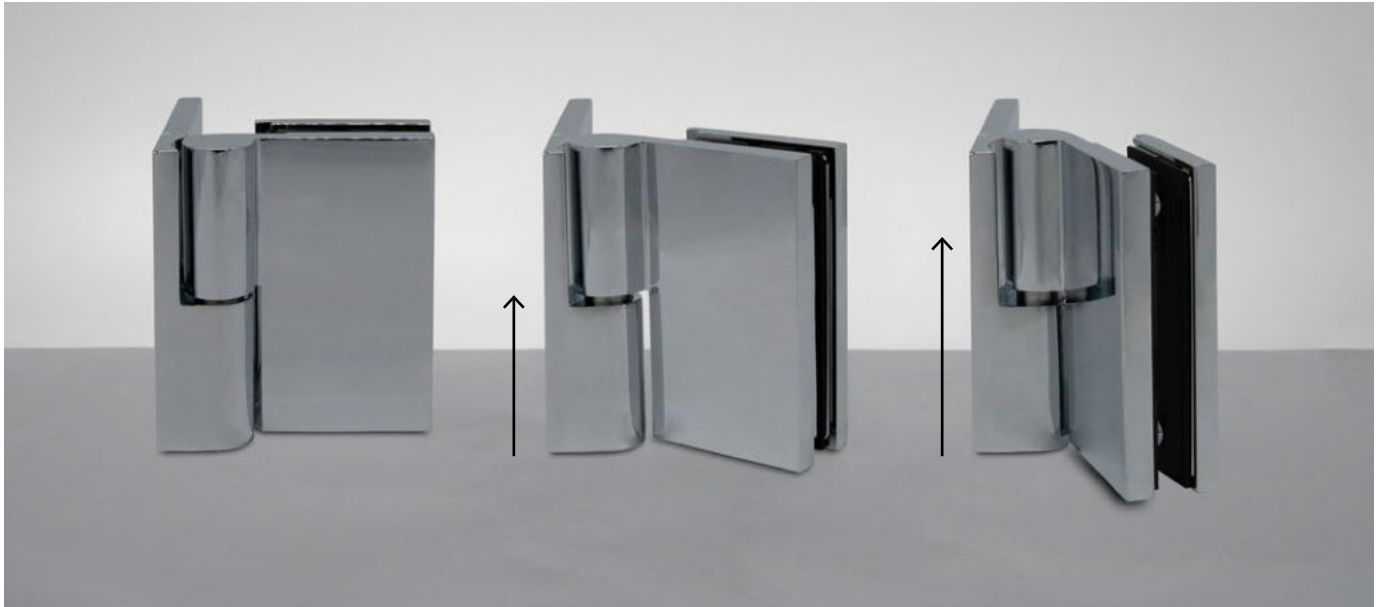

**EIGENSCHAFTEN**  
FEATURES

MAX. TÜRMÄÙE  
MAX. DOOR DIMENSIONS  
900 x 2.250 mm

GLAS (ESG)  
GLASS (TSG)  
8 mm

TÜRGEWICHT  
DOOR WEIGHT  
35 kg

**OBERFLÄCHEN**  
FINISHES

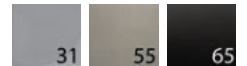

Sonderoberflächen möglich  
other finishes on request

**ANSCHLAGTÜRSYSTEM**  
SINGLE ACTION DOOR SYSTEM

**FUNKTIONEN**  
FEATURES

Einstellbare Nulllage  
Adjustable index position  
Durchgehende Dichtung (By-Pass-System)  
Continuous seal (By-Pass-System)  
Hebe-Senk Mechanismus  
Gravity based lifting hinge  
Vollabgedeckte Verschraubung  
Covered backplate, no visible screws

Adjustable index position  
Continuous seal (By-Pass-System)  
Gravity based lifting hinge  
Covered backplate, no visible screws

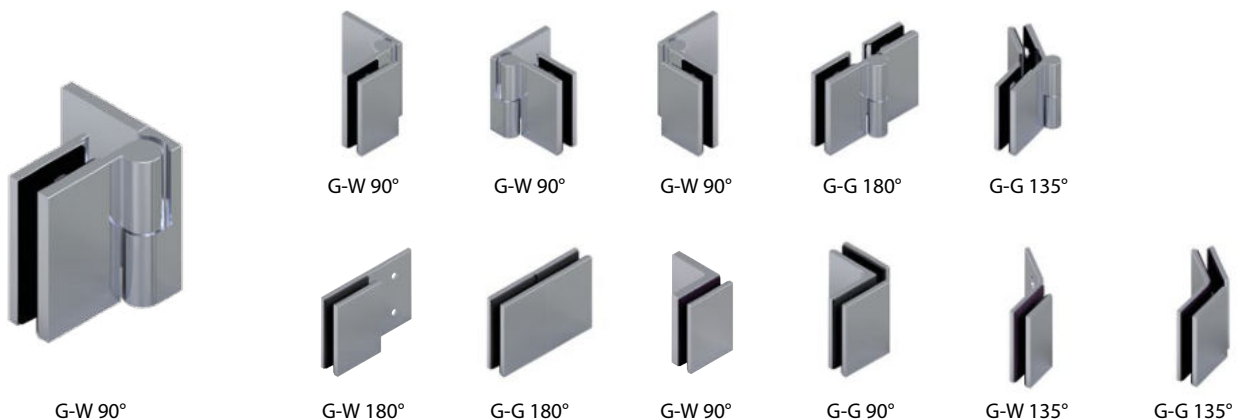

ANSCHLAGTÜRSYSTEM  
SINGLE ACTION DOOR SYSTEM



# WELLNESS HS CL

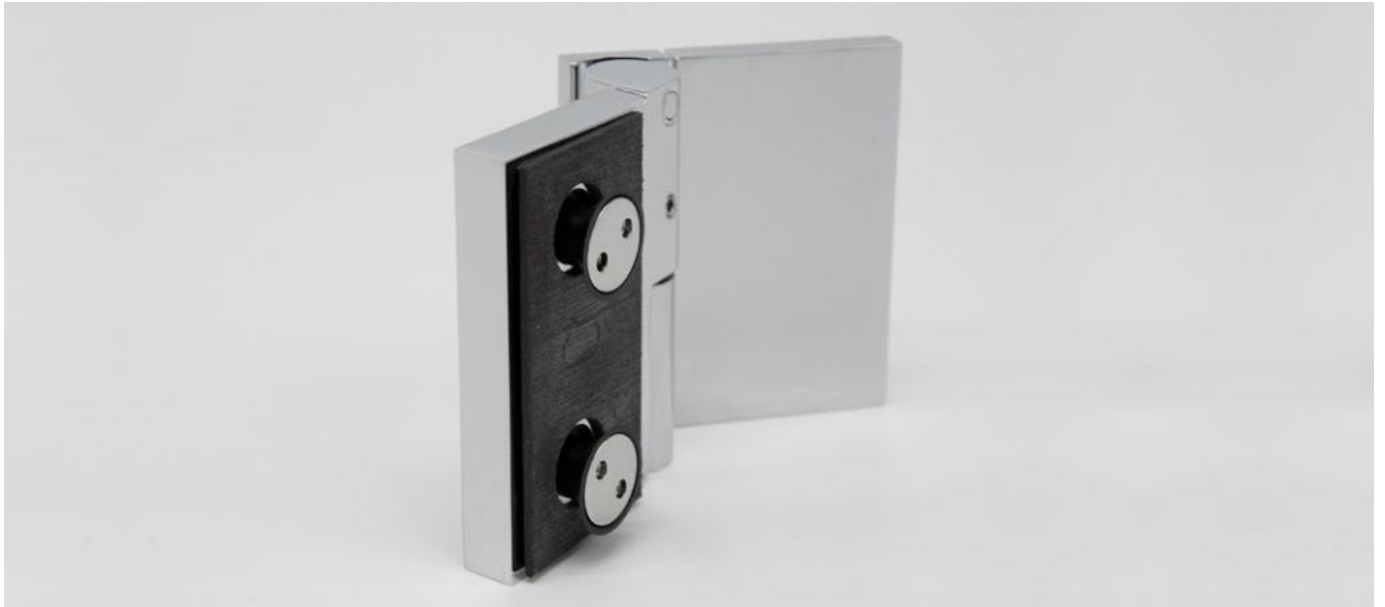

**EIGENSCHAFTEN**  
FEATURES

MAX. TÜRMÄÙE  
MAX. DOOR DIMENSIONS  
900 x 2.250 mm

GLAS (ESG)  
GLASS (TSG)  
8 mm

TÜRGEWICHT  
DOOR WEIGHT  
35 kg

**OBERFLÄCHEN**  
FINISHES

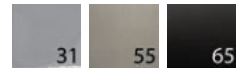

Sonderoberflächen möglich  
other finishes on request

**ANSCHLAGTÜRSYSTEM**  
SINGLE ACTION DOOR SYSTEM

**FUNKTIONEN**  
FEATURES

Einstellbare Nulllage  
Flächenbündige Verschraubung  
Durchgehende Dichtung (By-Pass-System)  
Hebe-Senk Mechanismus

Adjustable index position  
Countersunk screws  
Continuous seal (By-Pass-System)  
Gravity based lifting hinge







# CLASSTEC® Bella



**EIGENSCHAFTEN**  
FEATURES

MAX. TÜRMASSE  
MAX. DOOR DIMENSIONS  
**1.000 x 2.250 mm**

GLAS (ESG)  
GLASS (TSG)  
**8 mm**

TÜRGEWICHT  
DOOR WEIGHT  
**40 kg**

**OBERFLÄCHEN**  
FINISHES



31

Sonderoberflächen möglich  
other finishes on request

**ANSCHLAGTÜRSYSTEM**  
SINGLE ACTION DOOR SYSTEM

**FUNKTIONEN**  
FEATURES

Vollabgedeckte Verschraubung

Covered backplate



G-W 90°



G-W 90°



G-W 90°



G-G 90° & 180°



G-W 90°



G-G 90°



# MILANO



**EIGENSCHAFTEN**  
FEATURES

MAX. TÜRMASSE  
MAX. DOOR DIMENSIONS  
1.000 x 2.250 mm

GLAS (ESG)  
GLASS (TSG)  
8 & 10 mm

TÜRGEWICHT  
DOOR WEIGHT  
40 kg

**OBERFLÄCHEN**  
FINISHES



Sonderoberflächen möglich  
other finishes on request

**PENDELTÜRSYSTEM**  
DOUBLE ACTION DOOR SYSTEM

**FUNKTIONEN**  
FEATURES

Einstellbare Nulllage

Adjustable index posi

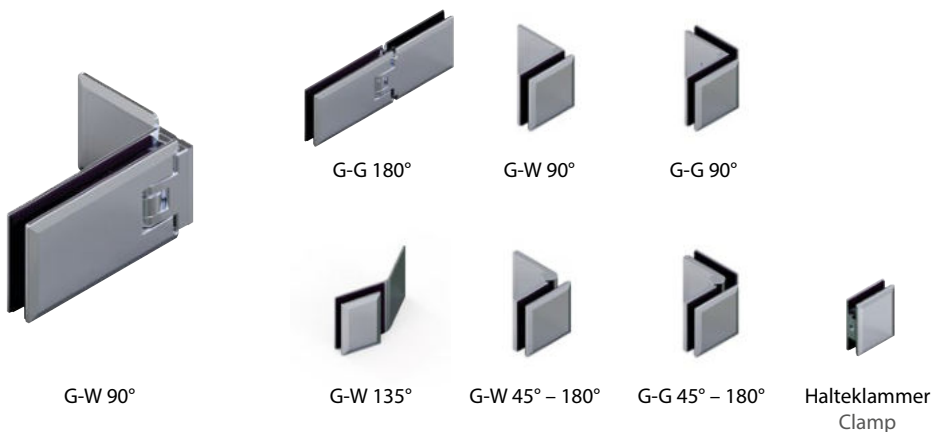



# MILANO PUR



**EIGENSCHAFTEN**  
FEATURES

MAX. TÜRMASSE  
MAX. DOOR DIMENSIONS  
1.000 x 2.250 mm

GLAS (ESG)  
GLASS (TSG)  
8 & 10 mm

TÜRGEWICHT  
DOOR WEIGHT  
40 kg

**OBERFLÄCHEN**  
FINISHES

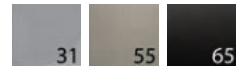

Sonderoberflächen möglich  
other finishes on request

**PENDELTÜRSYSTEM**  
DOUBLE ACTION DOOR SYSTEM

**FUNKTIONEN**  
FEATURES

Einstellbare Nulllage

Adjustable index position

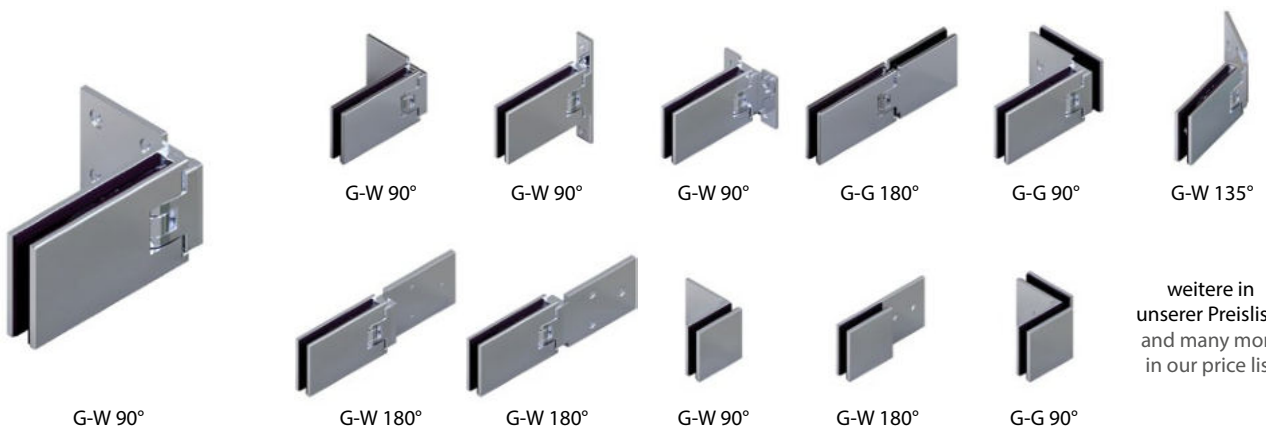

weitere in  
unserer Preisliste  
and many more  
in our price list



# MILANO ORIGINAL

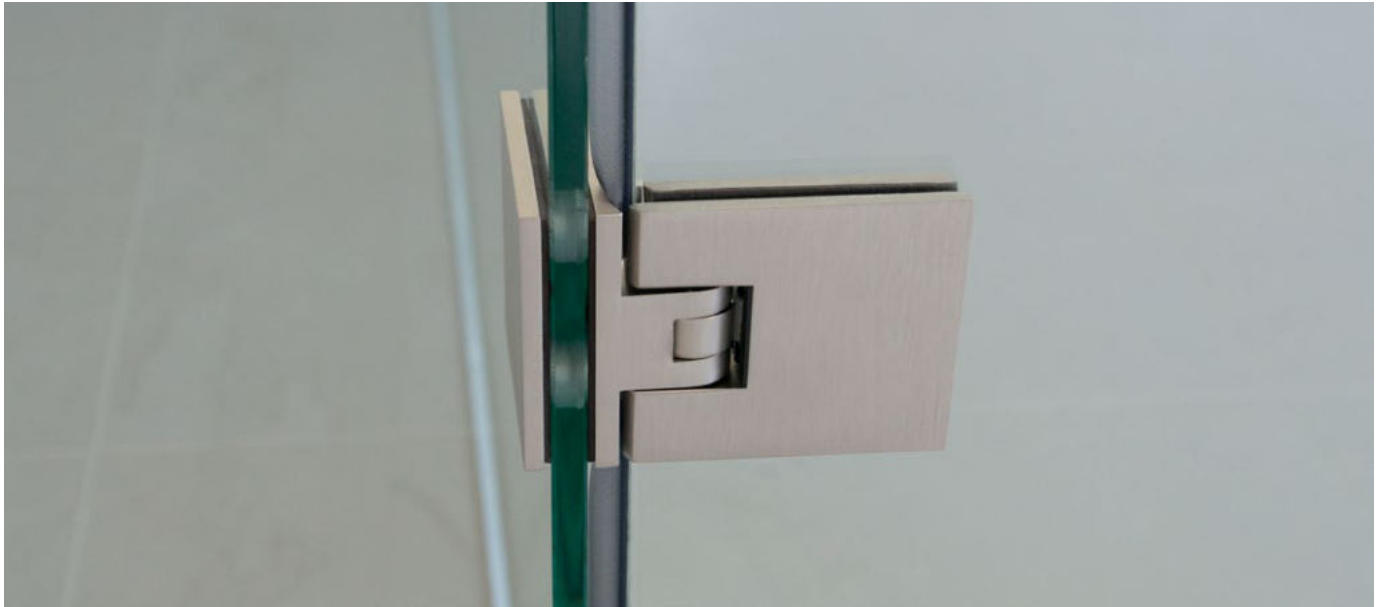

**EIGENSCHAFTEN**  
FEATURES

MAX. TÜRMASSE  
MAX. DOOR DIMENSIONS  
1.000 x 2.250 mm

GLAS (ESG)  
GLASS (TSG)  
8 & 10 mm

TÜRGEWICHT  
DOOR WEIGHT  
50 kg

**OBERFLÄCHEN**  
FINISHES

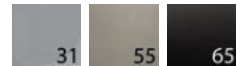

Sonderoberflächen möglich  
other finishes on request

**PENDELTÜRSYSTEM**  
DOUBLE ACTION DOOR SYSTEM

**FUNKTIONEN**  
FEATURES

Einstellbare Nulllage  
Vollabgedeckte Verschraubung  
Als Saunavariante erhältlich

Adjustable index position  
Covered backplate  
Sauna type hinge available

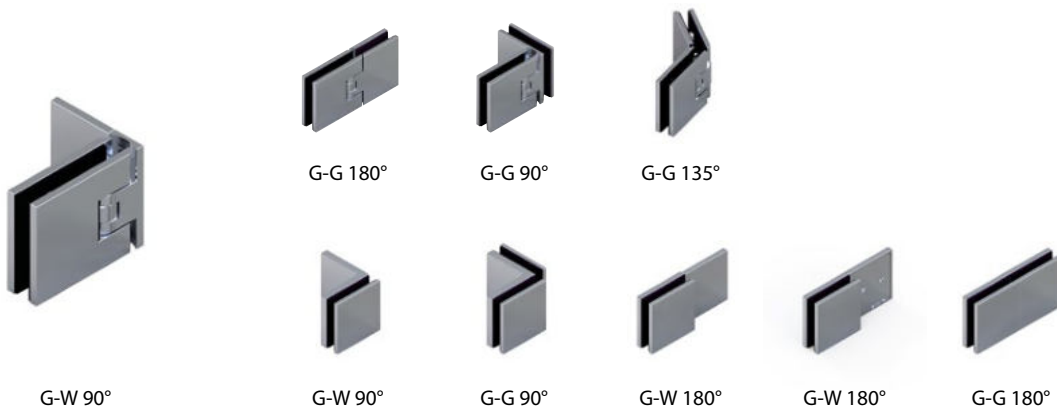





# MILANO ORIGINAL PREMIUM



**EIGENSCHAFTEN**  
FEATURES

MAX. TÜRMASSE  
MAX. DOOR DIMENSIONS  
1.100 x 2.250 mm

GLAS (ESG)  
GLASS (TSG)  
8 & 10 mm

TÜRGEWICHT  
DOOR WEIGHT  
50 kg

**OBERFLÄCHEN**  
FINISHES

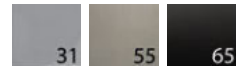

Sonderoberflächen möglich  
other finishes on request

**PENDELTÜRSYSTEM**  
DOUBLE ACTION DOOR SYSTEM

**FUNKTIONEN**  
FEATURES

Einstellbare Nulllage  
3-Punkt-Nulllage  
geschlossene Bandrolle  
Vollabgedeckte Verschraubung

Adjustable index position  
3-Point index position  
hidden index cylinder  
Covered screws

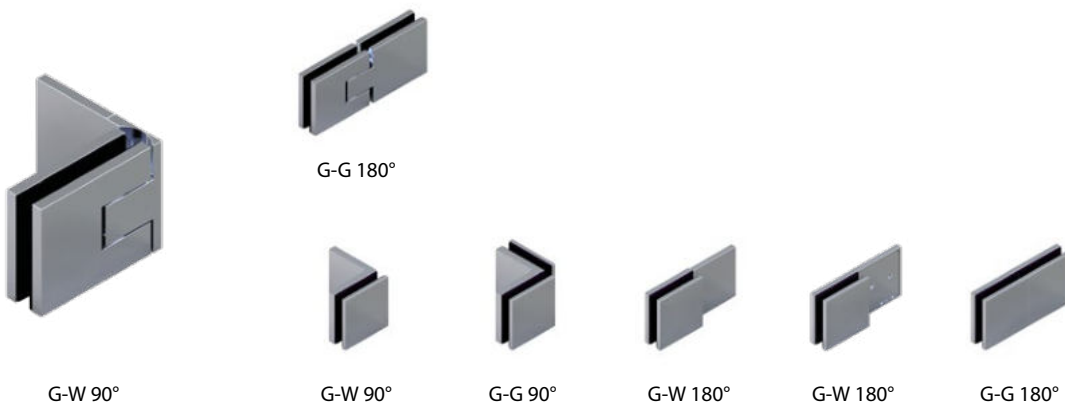



# NEXT HS



**EIGENSCHAFTEN**  
FEATURES

MAX. TÜRMASSE  
MAX. DOOR DIMENSIONS  
1000 x 2.250 mm

GLAS (ESG)  
GLASS (TSG)  
8 & 10 mm

TÜRGEWICHT  
DOOR WEIGHT  
40 kg

**OBERFLÄCHEN**  
FINISHES

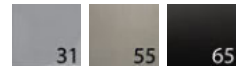

Sonderoberflächen möglich  
other finishes on request

**PENDELTÜRSYSTEM**  
DOUBLE ACTION DOOR SYSTEM

**FUNKTIONEN**  
FEATURES

Einstellbare Nulllage  
Ca. 5 mm Hebe-Senk Mechanismus  
In das Band integrierte Dichtung  
Vollabgedeckte Verschraubung

Adjustable index position  
Approx. 5 mm gravity based lifting hinge  
Integrated seal in hinge  
Covered backplate



G-W 90°



G-G 180°



G-W 90°



G-G 90°

weitere in  
unserer Preisliste  
and many more  
in our price list

PENDELTÜRSYSTEM  
DOUBLE ACTION DOOR SYSTEM



# NEXT HS CL



**EIGENSCHAFTEN**  
FEATURES

MAX. TÜRMASSE  
MAX. DOOR DIMENSIONS  
1000 x 2.250 mm

GLAS (ESG)  
GLASS (TSG)  
8 & 10 mm

TÜRGEWICHT  
DOOR WEIGHT  
40 kg

**OBERFLÄCHEN**  
FINISHES

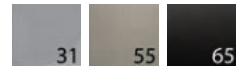

Sonderoberflächen möglich  
other finishes on request

**PENDELTÜRSYSTEM**  
DOUBLE ACTION DOOR SYSTEM

**FUNKTIONEN**  
FEATURES

Einstellbare Nulllage  
Flächenbündige Verschraubung  
Ca. 5 mm Hebe-Senk Mechanismus  
In das Band integrierte Dichtung  
Verbauung ohne Dichtprofile möglich

Adjustable index position  
Countersunk screws  
Approx. 5 mm gravity based lifting hinge  
Integrated seal in hinge  
Can be mounted without seals



G-W 90°



G-G 180°



G-W 90°



G-G 90°

weitere in  
unserer Preisliste  
and many more  
in our price list



# CLASSTEC® Vital



**EIGENSCHAFTEN**  
FEATURES

MAX. TÜRMASSE  
MAX. DOOR DIMENSIONS  
**1.000 x 2.000 mm**

GLAS (ESG)  
GLASS (TSG)  
**8 mm**

TÜRGEWICHT  
DOOR WEIGHT  
**40 kg**

**OBERFLÄCHEN**  
FINISHES



Sonderoberflächen möglich  
other finishes on request

**PENDELTÜRSYSTEM**  
DOUBLE ACTION DOOR SYSTEM

**FUNKTIONEN**  
FEATURES

Stufenlos einstellbare Nulllage

Adjustable index position



G-W 90°



G-G 180°



G-W 90°



G-G 90°







## KL MEGLA ZUBEHÖR

### ACCESSORIES

Qualität und Sicherheit sind Prämissen, die sich durch unser komplettes Produktportfolio ziehen. Denn auch vermeintliche Kleinigkeiten können über die Stabilität und Haltbarkeit einer Glastüranlage entscheiden. Wir fertigen wir unser Zubehör passend zu unseren Beschlägen an und setzen auch bei unseren Stabilisationsstangen und Griffen auf hochwertiges Messing und Edelstahl.

Bei unseren Dichtprofilen haben Sie die Wahl zwischen Klebe-, Aufsteck- und Magnetdichtprofilen.

Ensuring quality and safety is a major point in our product through our complete product portfolio. Because even little things can influence the stability and durability of a glass door system. We manufacture our accessories to match our fittings and also use high-quality brass and stainless steel for our stabilizing bars and handles.

With our sealing profiles you have the choice between adhesive, plug-on and magnetic sealing profiles.

# HANDTUCHHALTER

## TOWEL BARS

Basismaterial: hochwertiges Messing base material: high quality brass



**Art. No. 06706 – Stratego**  
G-G, Rohrlänge 1000 mm, 8 mm ESG  
g-g, bar length 1000 mm, 8 mm tempered glass



**Art. No. 06709 – Stratego**  
G-G, Rohrlänge 1000 mm mit Griff, 8 mm ESG  
g-g, bar length 1000 mm, with door handle, 8 mm tempered glass



**Art. No. 06710 – Stratego**  
Fächenbündige Verschraubung, Rohrlänge 1000 mm, 8 mm ESG  
Flush screw, bar length 1000 mm, 8 mm tempered glass

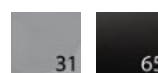

**Art. No. 06730 – Filigrano eckig square**  
G-G, Stablänge 1000 mm, 8 mm ESG  
g-g bar length 1000 mm, 8 mm tempered glass

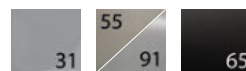

Vierkantstab aus hochwertigem  
Edelstahl matt gebürstet (OF 91)  
Square bar is made of brushed  
stainless steel (finish 91)



**Art. No. 06731 – Filigrano eckig square**  
G-G, Stablänge 1000 mm, mit Griff, 8 mm ESG  
g-g bar length 1000 mm, with handle, 8 mm tempered glass

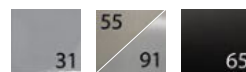

Vierkantstab aus hochwertigem  
Edelstahl matt gebürstet (OF 91)  
Square bar is made of brushed  
stainless steel (finish 91)



**Art. No. 06740 – Filigrano rund round**  
G-G, Stablänge 1000 mm, 8 mm ESG  
g-g, bar length 1000 mm, 8 mm tempered glass

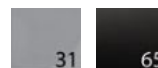

**Art. No. 06741 – Filigrano rund round**  
G-G, Stablänge 1000 mm, mit Griff, 8 mm ESG  
g-g, bar length 1000 mm, with door handle, 8 mm tempered glass



# STRATEGO

## STABILISATIONSSTANGEN SUPPORT BARS

Basismaterial: hochwertiges Messing base material: high quality brass



**Art. No. 67070**

Deckenmontage G-D, Rohrlänge max. 500 mm, 8 mm ESG  
Ceiling installation g-c, bar length max. 500 mm, 8 mm tempered glass



**Art. No. 67078**

G-W 45° Rohrlänge 500 mm, rechte & linke Scheibe, 8 mm ESG  
g-w 45°, bar length 500 mm, right & left panel, 8 mm tempered glass



**Art. No. 67080 & 67085**

G-W 90°, Rohrlänge 1000 & 1500 mm, 8 mm ESG  
g-w 90°, bar length 1000 & 1500 mm, 8 mm tempered glass



**Art. No. 67087 & 67088**

G-W 90°, Bohrung im Glas, Rohrlänge 1000 & 1500 mm, 8 mm ESG  
g-w 90°, drill hole in glass, bar length 1000 & 1500 mm, 8 mm tempered glass



**Art. No. 67090 & 67095**

G-G, Rohrlänge 1000 & 1500 mm, 8 mm ESG  
g-g, bar length 1000 & 1500 mm, 8 mm tempered glass



**Art. No. 67096**

T-Stück mit 90° Glasaufnahme, verschiebbar, Rohrlänge 100 mm, 8 mm ESG  
t-unit with 90° glass adapter, moveable, bar length 100 mm, 8 mm tempered glass



# FILIGRANO

## STABILISATIONSSTANGEN SUPPORT BARS

Basismaterial: hochwertiges Messing base material: high quality brass



**Art. No. 67160 & 67180**

G-W, verstellbar +/- 90°, Stablänge 1050 & 1500 mm, 6 - 8 mm  
g-w, adjustable +/- 90°, bar length 1050 & 1500 mm,  
6 - 8 mm tempered safety glass



**Art. No. 67161 & 67181**

G-W, verstellbar +/- 90°, Stablänge, 1050 & 1500 mm, 10 - 12 mm ESG  
g-w, adjustable, +/- 90°, bar length 1050 & 1500 mm,  
10 - 12 mm tempered safety glass



**Art. No. 67162 & 67182**

G-G, verstellbar 0 - 360°, Stablänge, 1050 & 1500 mm, 6 - 8 mm ESG  
g-g, adjustable 0 - 360°, bar length 1050 & 1500 mm,  
6 - 8 mm tempered safety glass



**Art. No. 67163 & 67183**

G-G, verstellbar 0 - 360°, Stablänge, 1050 & 1500 mm, 10 - 12 mm ESG  
g-g, adjustable, 0 - 360°, bar length 1050 & 1500 mm  
10 - 12 mm tempered safety glass



**Art. No. 67110 & 67112**

G-W, Stablänge 1050 & 1500 mm, 8 mm ESG  
g-w, bar length 1050 & 1500 mm, 8 mm tempered safety glass



**Art. No. 67120 & 67122**

G-G, Stablänge 1050 & 1500 mm, 8 mm ESG  
g-g, bar length 1050 & 1500 mm, 8 mm tempered safety glass



**Art. No. 67130 & 67132**

G-W 45°, Stablänge 1050 & 1500 mm, 8 mm ESG  
g-w 45°, bar length 1050 & 1500 mm, 8 mm tempered safety glass

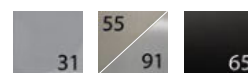

Vierkantstab aus hochwertigem  
Edelstahl matt gebürstet (OF 91)  
Square bar is made of brushed  
stainless steel (finish 91)

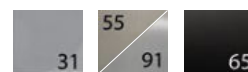

Vierkantstab aus hochwertigem  
Edelstahl matt gebürstet (OF 91)  
Square bar is made of brushed  
stainless steel (finish 91)

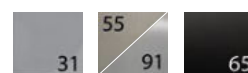

Vierkantstab aus hochwertigem  
Edelstahl matt gebürstet (OF 91)  
Square bar is made of brushed  
stainless steel (finish 91)

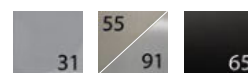

Vierkantstab aus hochwertigem  
Edelstahl matt gebürstet (OF 91)  
Square bar is made of brushed  
stainless steel (finish 91)

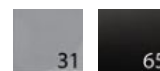
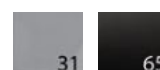
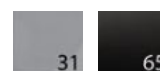

Weitere Ausführungen und Komponenten finden Sie in unserer Preisliste.  
You'll find more variations and components in our price list.



## FUNKTIONAL & SCHÖN

FUNCTIONAL & GOOD-LOOKING

**Art. No. 05014 & 05015**

beidseitig mit Puffer. Ideal für Faltlösungen  
double-sided with buffers, ideal for folding doors

# TÜRGRIFFE

## DOOR HANDLES

Basismaterial: hochwertiges Messing base material: high quality brass



**Art. No. 80401**  
Ø 32 mm, beidseitig, für 8 mm ESG  
Ø 32 mm, double-sided, for 8 mm tempered glass



**Art. No. 05003 & 05007**  
Ø 35 mm & Ø 32 mm, beidseitig, für 6-12 mm ESG  
Ø 35 mm, double-sided, for 6-12 mm tempered glass

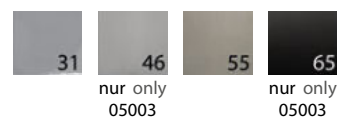

**Art. No. 05013**  
Ø 35 mm, beidseitig, Puffer einseitig auf der flachen Seite, für 6-12 mm ESG  
Ø 35 mm, double-sided, buffer on the flat side, for 6-12 mm tempered glass

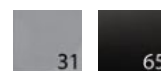

**Art. No. 05014 & 05015**  
Ø 35 mm, beidseitig, mit Puffer beidseitig, für 6-12 mm ESG  
Ø 35 mm, double-sided, with buffer on both sides, for 6-12 mm tempered glass

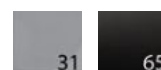

**Art. No. 05030**  
30 x 30 x 30 x 30 mm, beidseitig, eckige Form, für 6-12 mm ESG  
30 x 30 x 30 x 30 mm, double-sided, square design,  
for 6-12 mm tempered glass



**Art. No. 05032**  
30 x 30 x 30 mm, beidseitig, eckige Form, Puffer auf der flachen Seite,  
für 6-12 mm ESG  
30 x 30 x 30 mm, double-sided, square design, buffer on the flat side,  
for 6-12 mm tempered glass



# CHALET AT



**EIGENSCHAFTEN**  
FEATURES

MAX. TÜRMASSE  
MAX. DOOR DIMENSIONS  
1.000 x 2.100 mm

GLAS (ESG)  
GLASS (TSG)  
8 mm

TÜRGEWICHT  
DOOR WEIGHT  
45 kg

**OBERFLÄCHEN**  
FINISHES

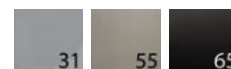

Sonderoberflächen möglich  
other finishes on request

**ANSCHLAGTÜRSYSTEM**  
SINGLE ACTION DOOR SYSTEM

**FUNKTIONEN**  
FEATURES

Selbstschließend, Softclose  
Einstellbare Schließgeschwindigkeit  
Vollabgedeckte Verschraubung  
Als Saunavariante erhältlich

Self-closing, Softclose  
Adjustable closing speed  
Covered backplate, no visible screws  
Sauna type hinge available



G-W 90°



G-G 180°

weitere in  
unserer Preisliste  
and many more  
in our price list





# CHALET PT



**EIGENSCHAFTEN**  
FEATURES

MAX. TÜRMASSE  
MAX. DOOR DIMENSIONS  
1.000 x 2.500 mm

GLAS (ESG)  
GLASS (TSG)  
10 mm

TÜRGEWICHT  
DOOR WEIGHT  
65 kg

**OBERFLÄCHEN**  
FINISHES

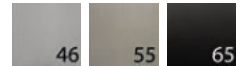

Sonderoberflächen möglich  
other finishes on request

**PENDELTÜRSYSTEM**  
DOUBLE ACTION DOOR SYSTEM

**BESONDERHEITEN**  
HIGHLIGHTS

Einstellbare Nulllage (+/- 2,5°)  
Selbstschließend

Adjustable index position (+/- 2,5°)  
Self-closing



G-W 90°



G-G 180°

weitere in  
unserer Preisliste  
and many more  
in our price list





## BESCHLÄGE FÜR SAUNA & SPA

### HARDWARE FOR SAUNA & SPA

Folgende Beschlagserien erhalten Sie bei uns als Saunavariante:  
Following hinge series are available for sauna:



**Milano Original therma**



**Chalet AT therma**



**Sauna Türgriffe**  
Sauna door handles





**BRÄSSWORKS**  
individual hardware for glass

## MOTIVA

CNC Gravuren & Sonderoberflächen  
CNC engraving & Custom Finishes



## STANDARD OBERFLÄCHEN

### STANDARD FINISHES

Weitere Oberflächen finden Sie in unserer Preisliste | More finishes can be found in our price list

10	Silberfarbig eloxiert	Silver color anodized
31	Glanzverchromt	Bright chrome
46	Mattverchromt	Satin chrome
55	Nickel gebürstet (Edelstahloptik)	Brushed nickel (stainless steel look)
65	ONYX schwarz	ONYX black
91	Edelstahl gebürstet	Brushed stainless steel



**Milano**  
Glanzverchromt  
Bright chrome



**Chalet AT**  
Nickel gebürstet  
Brushed nickel



**Milano Original**  
ONYX schwarz  
ONYX black

## SONDER OBERFLÄCHEN

### SPECIAL FINISHES

36	Glanzvernickelt	Bright nickel
51	Mattvernickelt	Satin nickel
59	Messing Braun	Brown brass
61	Feingold	Fine gold
62	Gelbgold (Farbton ähnlich wie Messing)	Yellow gold (brass color)
63	Altkupfer gebürstet mit Klarlack	Brushed old copper with clear varnish <sup>o</sup>
64	Altbronze bebürstet mit Klarlack	Brushed old bronze with clear varnish <sup>o</sup>
67	Matt vergoldet	Satin gold plated
68	Vergoldet mit Roségold	Rosé gold plated <sup>o</sup>
69	Messing gebürstet mit Klarlack	Brushed brass with clear varnish <sup>o</sup>
81	RAL 9005 schwarz matt pulverbeschichtet	RAL 9005 matt black powder coated <sup>A)</sup>
82	RAL 9010 weiß matt pulverbeschichtet	RAL 9010 white matt powder coated <sup>A)</sup>
84	RAL 9005 schwarz glänzend pulverbeschichtet	RAL 9005 glossy black powder coated <sup>A)</sup>



**Milano**  
Gelbgold  
Yellow gold



**Wellness HS**  
Altkupfer gebürstet  
Brushed old copper



**Chalet PT**  
Altbronze gebürstet  
Brushed old bronze



**05003 Griff // Handle**  
Vergoldet mit Roségold  
Rosé gold plated

