

BILOBA 8015BTJC

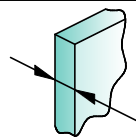

BILOBA

8015BTJC

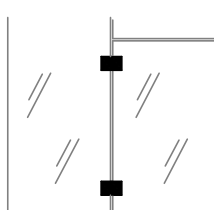
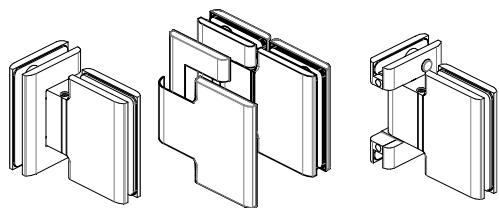

8 - 10 - 12

GLASS - VETRO - GLAS

Tools Required
Strumenti Richiesti
Benötigtes Werkzeug



CH-3

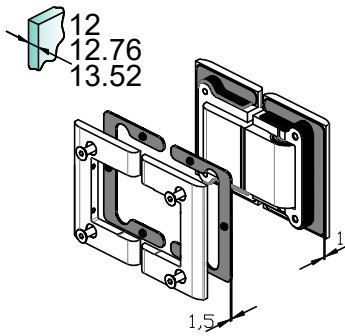
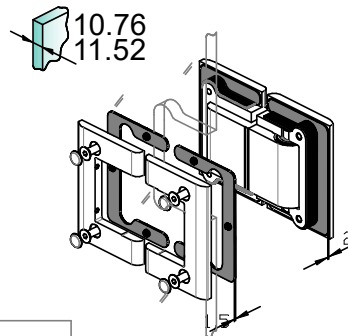
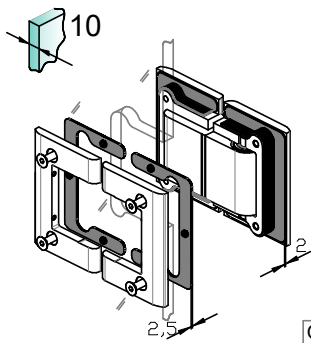
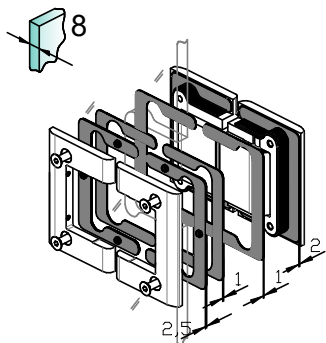

Gasket
Guarnizioni
Zwischenlagen

1

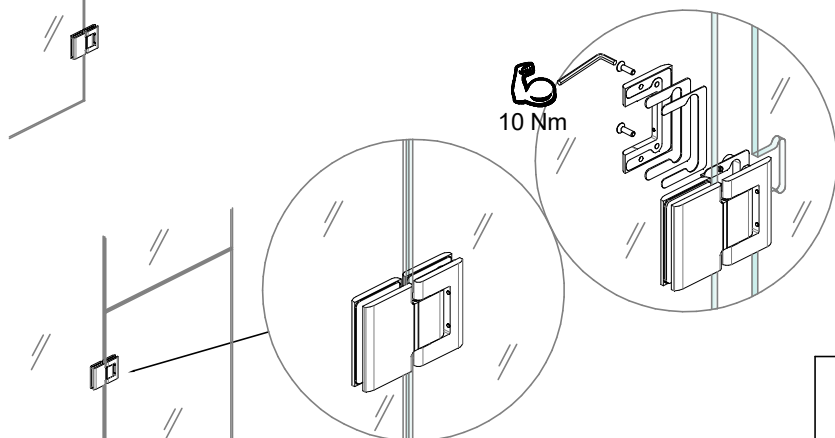
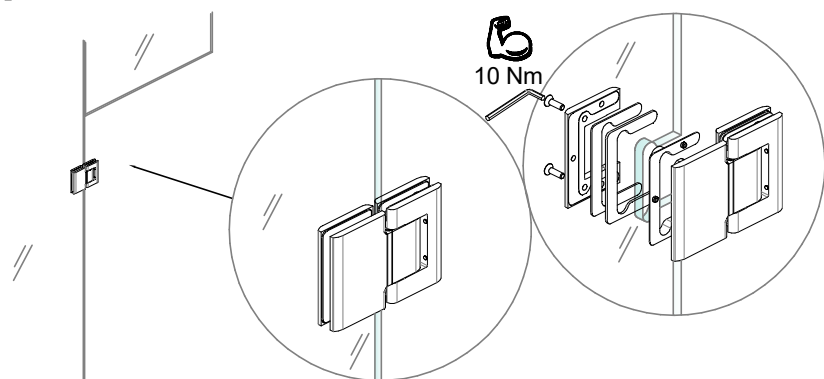

2

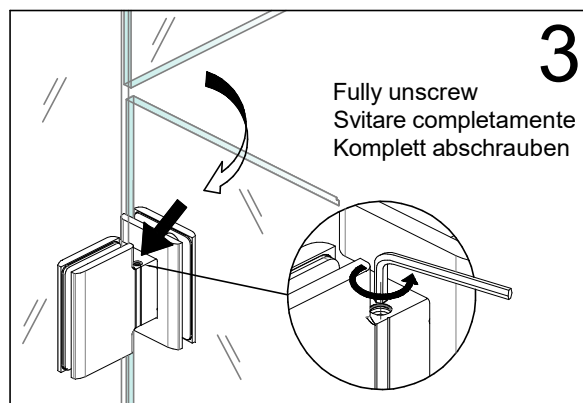
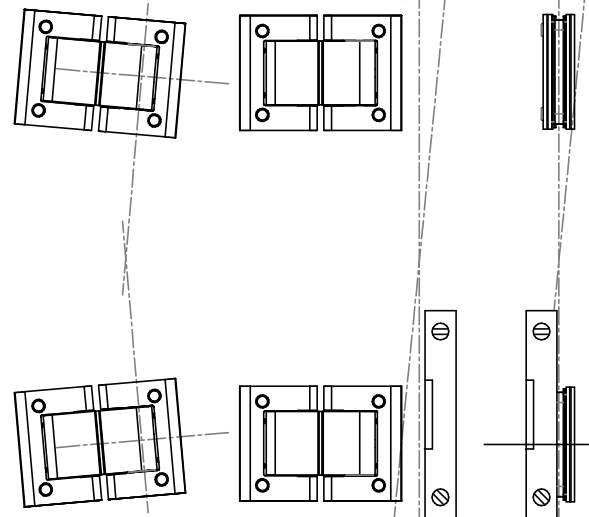

3

Fully unscrew
Svitare completamente
Komplett abschrauben

4 HORIZONTAL ALIGNMENT FOR EACH HINGE ALLINEAMENTO ORIZZONTALE PER OGNI CERNIERA HORIZONTALE AUSRICHTUNG FÜR JEDES BAND

first REC +
prima REC +
erst REC +

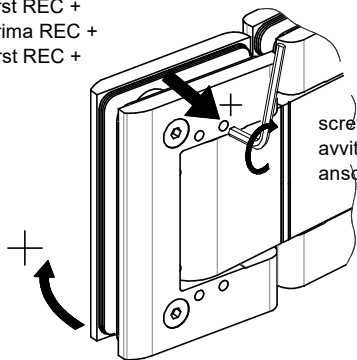

then LOCK
quindi BLOCCARE
dann VERSCHLIEßEN

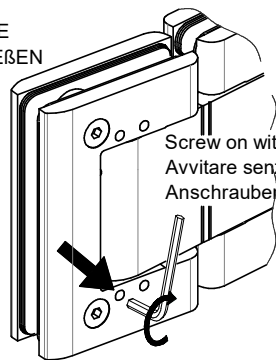

then LOCK
quindi BLOCCARE
dann VERSCHLIEßEN

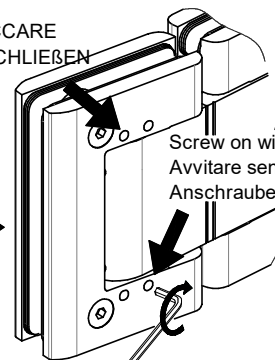

screw on
avvitare
anschrauben

Screw on without forcing
Avvitare senza forzare
Anschrauben ohne Gewalt

Screw on without forcing
Avvitare senza forzare
Anschrauben ohne Gewalt

first REC -
prima REC -
erst REC -

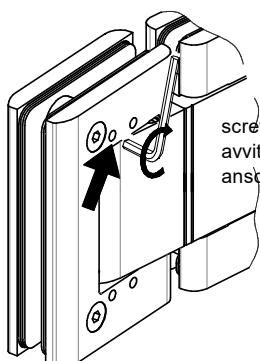

then LOCK
quindi BLOCCARE
dann VERSCHLIEßEN

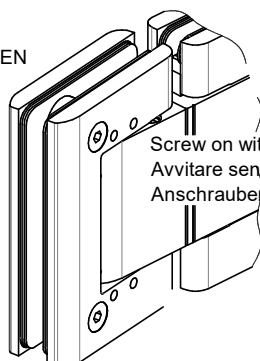

then LOCK
quindi BLOCCARE
dann VERSCHLIEßEN

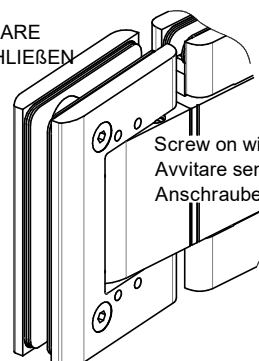

screw on
avvitare
anschrauben

Screw on without forcing
Avvitare senza forzare
Anschrauben ohne Gewalt

Screw on without forcing
Avvitare senza forzare
Anschrauben ohne Gewalt

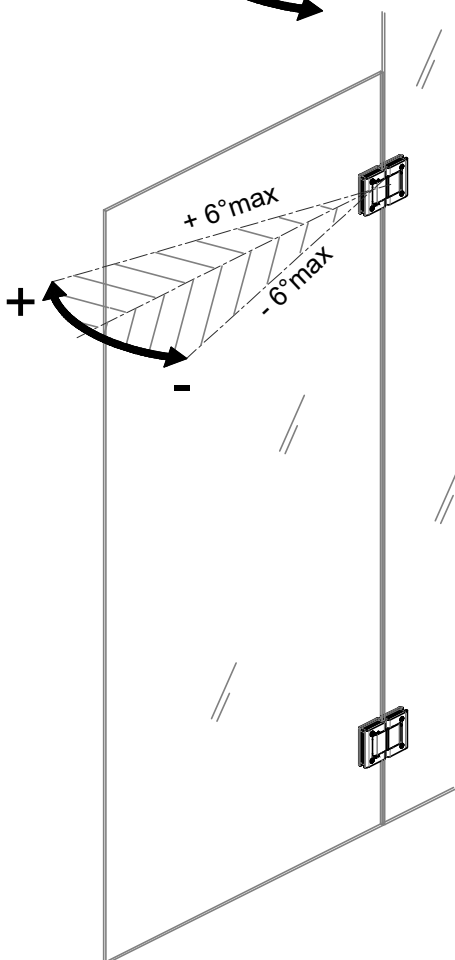

5

CLOSING SPEED ADJUSTING

REGOLAZIONE TEMPO DI CHIUSURA

EINSTELLUNG SCHLIEßGESCHWINDIGKEIT

Non per la versione SOL
Not for SOL version
Nicht für SOL version



WARNING: MOUNT THE COVERS ONLY AFTER THE HINGES HAVE
IMPORTANTE : MONTARE COPERTINE SOLO DOPO AVER INSTALLATO LE CERNIERE
WICHTIG: ABDECKUNGEN ERST NACH MONTAGE DER BÄNDER ANBRINGEN

1 MOUNTING OF WING'S COVER

- A) OPEN THE DOOR AND CENTRE THE COVER ON THE WING'S BASE SLOPING IT AS SHOWN IN THE DRAWING.
- B) TURN THE COVER AND VIGOROUSLY PUSH AT BOTH ENDS; THE COVER SHALL HOOK ON THE WIN; A CLOCK NOISE HAS TO BE HEARD.
- C) PUSH THE CURVED PART OF COVER AND ENTER THE LITTLE PIN IN THE APPROPRIATE SEAT (SEE DRAWING)

MONTAGGIO COPERTINA CORPO

- A) APRIRE PORTA E CENTRARE COPERTINA SULLA BASE DEL CORPO INCLINANDOLA COME DA FIGURA
- B) RUOTARE LA COPERTINA E PREMERE CON FORZA ALLE DUE ESTREMITA FACENDO AGGANCIARE LA COPERTINA ALL'ALETTA TRAMITE GLI APPOSITI AGGANCI FINO A SENTIRE "CLICK"
- C) SPINGERE LA PARTE CURVA DELLA COPERTINA E FARE ACCOPPIARE DENTINO CON APPOSITA SEDE.(VEDI IMMAGINE)

MONTAGE ABDECKUNG SEITENTEILELEMENT

- A) ÖFFNEN SIE DIE TÜR UND LEGEN DIE ABDECKUNG SCHRÄG AUF DAS SEITENTEIL WIE IM BILD GEZEIGT
- B) DREHEN SIE DIE ABDECKUNG UND DRÜCKEN SIE BEIDE ENDEN KRÄFTIG AUFS BAND; DIE ABDECKUNG SOLLTE AM BAND HACKEN; EIN KLICK-GERÄUSCH MUSS ERTÖNEN.
- C) DRÜCKEN SIE DEN GEBOGENEN TEIL DER ABDECKUNG UND SETZEN SIE DEN KLEINEN STIFT AN DER PASSENDE STELLE EIN (SIEHE ZEICHNUNG).

2 MOUNTING OF COVER PLATE'S COVER

- A) CENTRE THE COVER AS SHOWN IN THE DRAWING AND TURN IT IN THE DIRECTION INDICATED FROM THE ARROW. VIGOROUSLY PUSHING LET THE COVERS BE HOOKED ON THE COVER PLATE USING THE APPROPRIATE HOOKS.

MONTAGGIO COPERTINA COPERCHIO

- A) CENTRARE COPERTINA COME DA IMMAGINE E RUOTARLA NELLA DIREZIONE INDICATA DALLA FRECCIA, PREMENDO CON FORZA FARE AGGANCIARE LA COPERTINA AL COPERCHIO TRAMITE GLI APPOSITI AGGANCI

MONTAGE ABDECKUNG FLÜGELTEILELEMENT

- A) ZENTRIEREN SIE DIE ABDECKUNG WIE IN DER ZEICHNUNG GEZEIGT UND DREHEN SIE ES IN DIE VOM PFEIL ANGEGEBENE RICHTUNG. DRÜCKEN SIE DIE ABDECKUNG KRÄFTIG, SODASS SIE AM BAND AN HACKT.

PLATE'S COVER
COPERTINA COPERCHIO
ABDECKUNG
FLÜGELTEILELEMENT

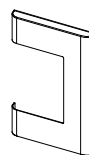

COMPLETE HINGE
CERNIERA COMPLETA
BAND VOLLSTÄNDIG

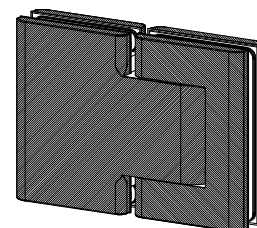

WING'S COVER
CORPO COPERTINA
ABDECKUNG
SEITENTEILELEMENT

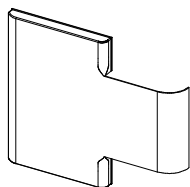

A

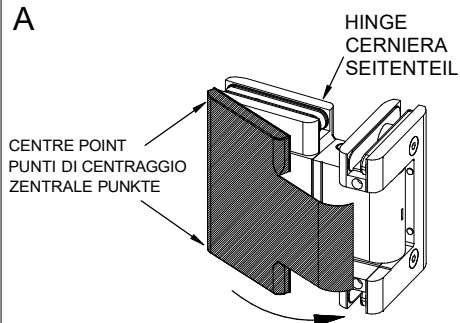

B

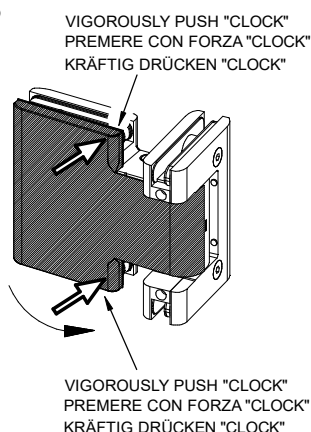

C

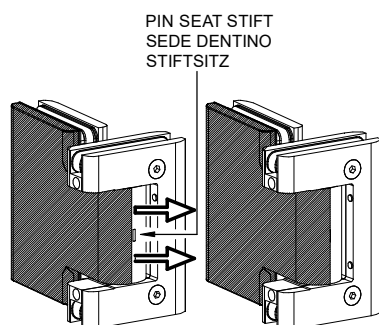

A

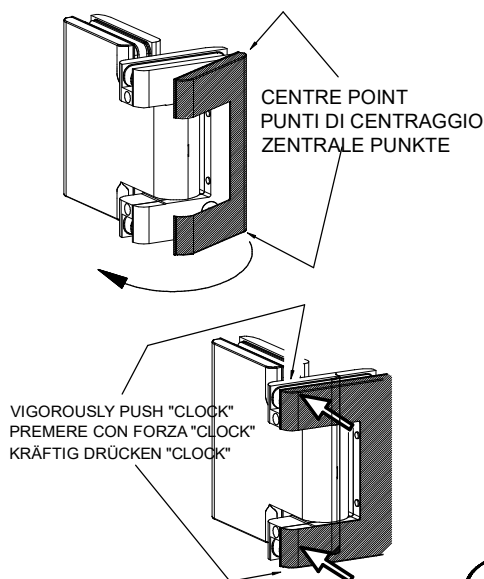

COLCOM®



N.B. REPEAT SAME STEPS FOR THE COVERS ON THE OPPOSITE SID
 N.B. RIPETERE LE STESSE OPERAZIONI PER LE COPERTINE SUL LATO OPPOSTO
 N.B. WIEDERHOLEN SIE DIE GLEICHEN SCHRITTE FÜR DIE ABDECKUNGEN AUF DER ANDEREN SEITE